

**NOW PLAYING**

MidNite  
SOLAR, inc



[WWW.MIDNITESOLAR.COM](http://WWW.MIDNITESOLAR.COM)  
425-374-9060

**MAGNA SINE E-PANEL**  
4000 WATT 24V  
INVERTER/CHARGER

**MIDNITE SOLAR PRESENTS**

# THE MIDNITE SOLAR E-PANEL

**SAVE \$700 ON INSTALLATION AND EQUIPMENT EXPENSES  
OVER COMPETING DISCONNECT AND BREAKER BOXES**



# Midnite Solar E-Panel (Magnum Version)

Inverter installation has just gone from hours to minutes!

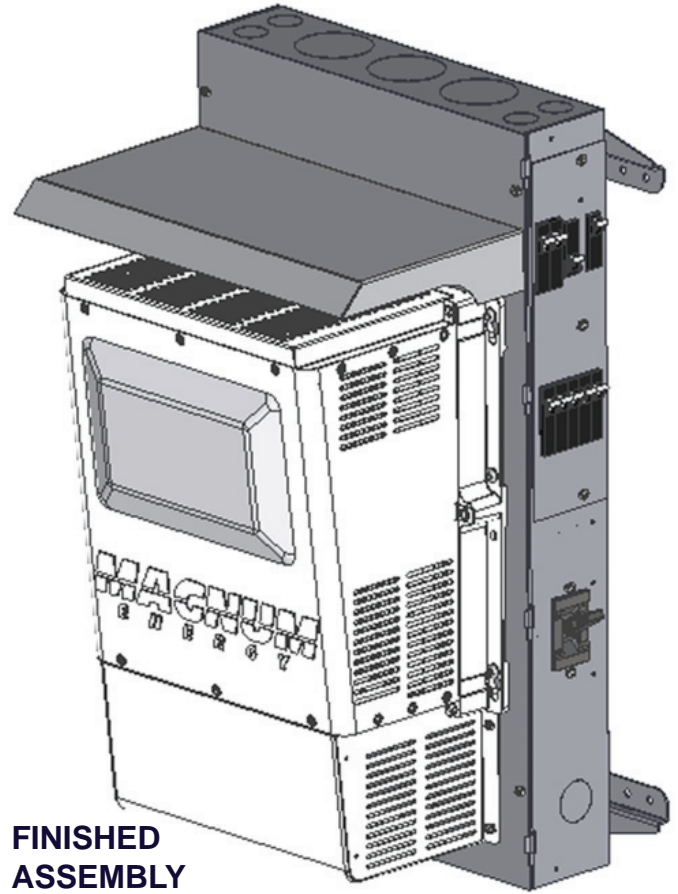
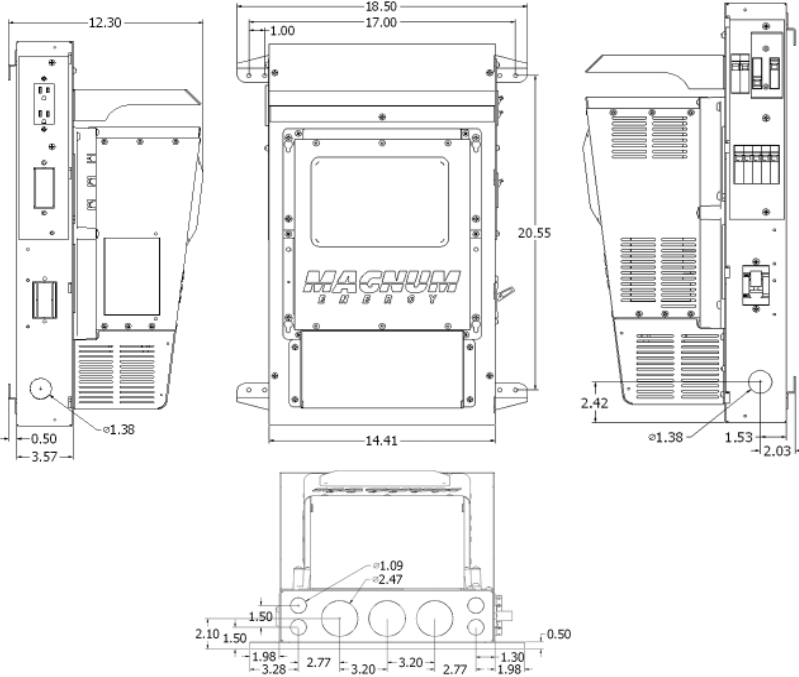

**FINISHED ASSEMBLY**

## FEATURES

- Small size compared to existing disconnect and over current solution
- Pre-wired to save time, money and complexity. All field wiring connections clearly labeled
- White powder coated aluminum or standard gray powder coated steel
- Easily expands to accommodate additional inverters
- Six slots for din rail breakers, PV, Wind, Hydro, AC distribution
- Pre-wired 50 amp 230VAC Inverter AC bypass switch
- Pre-wired 50 amp 240VAC AC Input disconnect
- Bus bars for Battery Plus, Battery Minus and ground
- Mounting hardware for Inverter and charge controller
- Mounting brackets for hanging E-Panel on wall
- Heavy duty 175 amp AC distribution block
- ETL listed to UL and Canadian standards
- Right hand hinged door to mount inverter
- Knockouts for AC and DC conduits
- Charge control bracket (CCB)
- Cut outs for two GFCI outlets
- DC Inverter battery breaker
- Internal inverter cables

## MODEL NUMBER CODE:

MNE.....175.....ST or AL.....M  
 Midnite E-Panel DC Inverter breaker Steel or Aluminum Magnum

Model No.	Sinewave Inverters	Modified Inverters	Price
MNE250STM	MS2012, MS2812, MS4024	RD3924	\$ 479
MNE250ALM	MS2012, MS2812, MS4024	RD3924	\$ 519
MNE175STM		RD1824, RD2824	\$ 479
MNE175ALM		RD1824, RD2824	\$ 519

- OPTIONS:**
- MNEleftdoorSTM - Left hand hinge steel door w/right hand CCB \$ 59
  - MNEleftdoorALM - Left hand hinge aluminum door w/right hand CCB \$ 65
  - MNEPV63 - 63 amp 125VDC din rail mount breaker \$ 15
  - MNDC-GFP - 63 amp DC GFP breaker assembly with 1/2amp trip \$ 65

See [www.outbackpower.com](http://www.outbackpower.com) for additional din rail mount breakers (OBAC & OBPV)  
 Prices do not include the Magnum Inverter.

See [www.midnitesolar.com](http://www.midnitesolar.com) for the evolution of the E-Panel  
 ETL tested an open E-Panel door with 360 pounds installed

Stacking horizontal or vertical is easy  
 Knock outs align top and bottom for vertical stacking  
 left hand door required for horizontal stacking

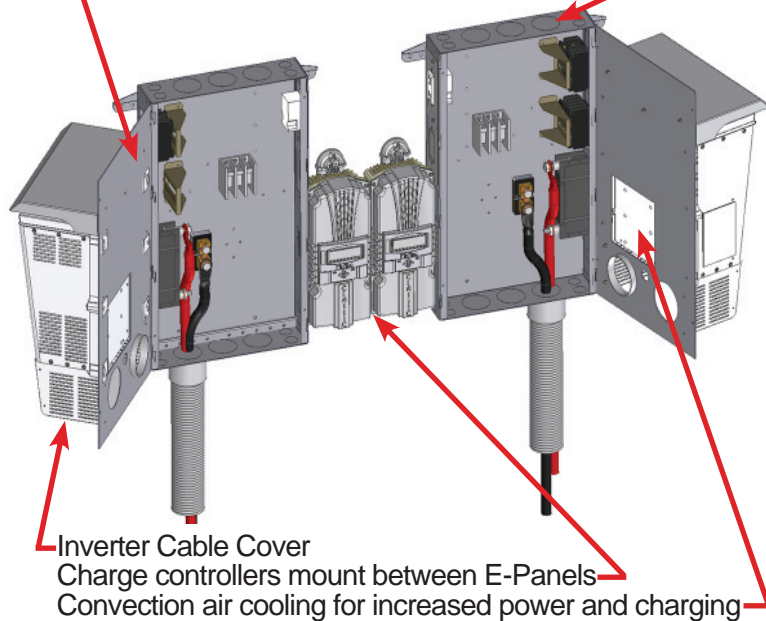

14000 Burn Road  
 ARLINGTON, WA 98223 USA  
 PHONE: 425-374-9060 FAX: 360-691-6862  
[www.midnitesolar.com](http://www.midnitesolar.com)

Support your local Installer

